

Service
Service
Service



Service Manual

AZ1017 is classified as exchange models.
This manual only gives some diagrams for basic repair in some regions.



TABLE OF CONTENTS

Service Partslist2

Block diagram3

CD Key board
 Circuit diagram4
 Layout diagram4

Tuner board
 Circuit diagram5
 Layout diagram6

Main board
 Circuit Diagram..... 7-9
 Layout diagram10-11



© Copyright 2006 Philips Consumer Electronics B.V. Eindhoven, The Netherlands
All rights reserved. No part of this publication may be reproduced, stored in a retrieval system or transmitted, in any form or by any means, electronic, mechanical, photocopying, or otherwise without the prior permission of Philips.

Published by YT 0612 Service Audio Subject to modification

GB 3141 785 31070

Version 1.0



PHILIPS

SERVICE PARTSLIST

9940 000 05116	BATTERY DOOR
9940 000 05117	CASSETTE DOOR
9940 000 05118	CD DOOR
9940 000 05113	CASSETTE DOOR SPRING
9940 000 05114	CD DOOR SPRING
9940 000 05115	CD DAMPER BLACK 658PH
9940 000 00168	CD DAMPER PINK 658F
9940 000 02364	ROD ANTENNA 2-SECTIONS L:420MM
9940 000 01476	CASSETTE DECK MECHANISM
9940 000 03392	CD MECHANISM DA11B3VF
9940 000 03283	ROTARY VOLUME F-122KGP B50K
4822 278 90739	CD DOOR SWITCH 1P2T LS-323-O
9940 000 05119	SPEAKER 8 OHM 1W 3 INCH
9940 000 03395	TRANSFORMER EI-41 120/230V
9940 000 05097	POWER CORD SET 5 FEET VDE APP.

SET BLOCK DIAGRAM

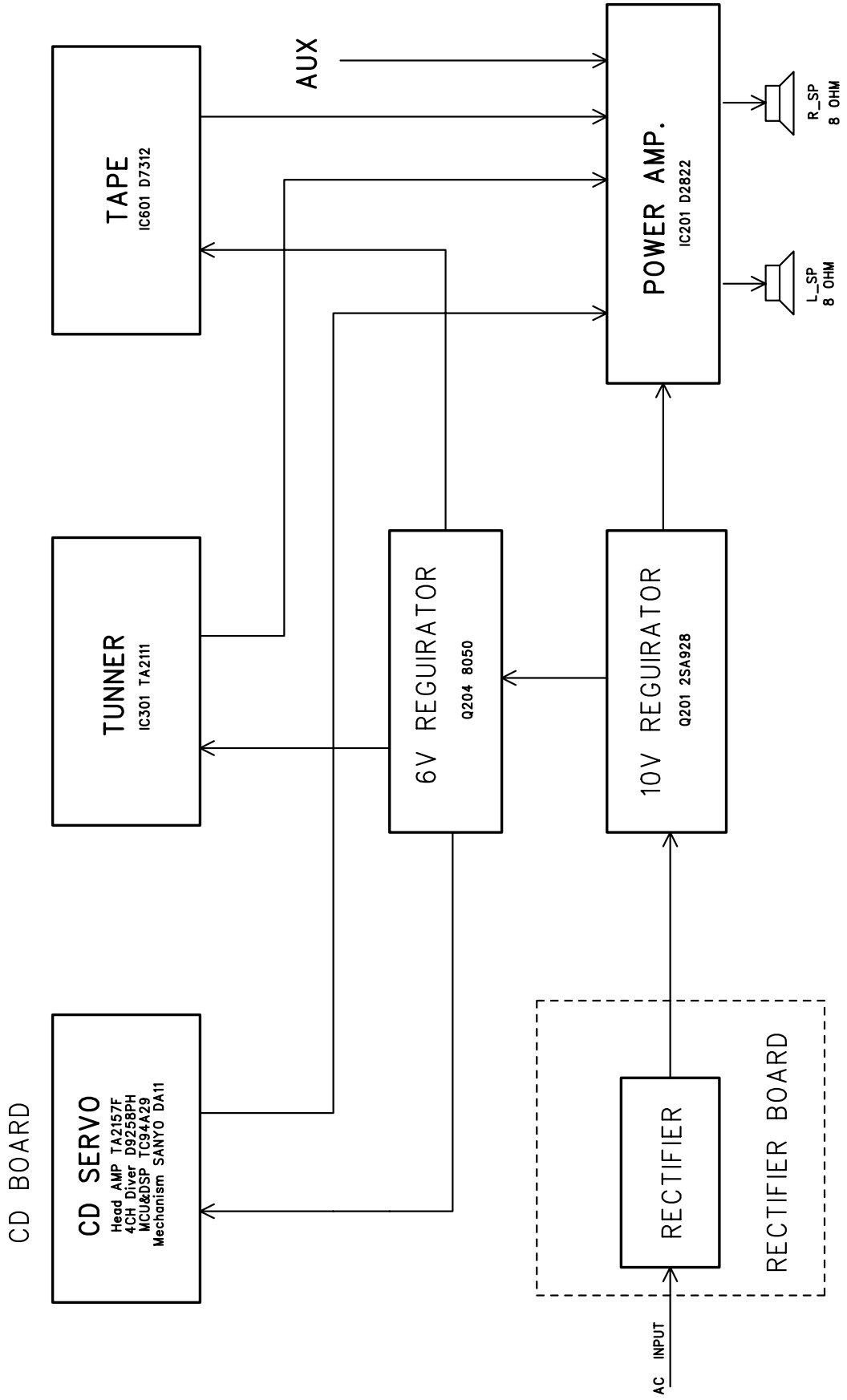

CD KEY BOARD - CIRCUIT DIAGRAM

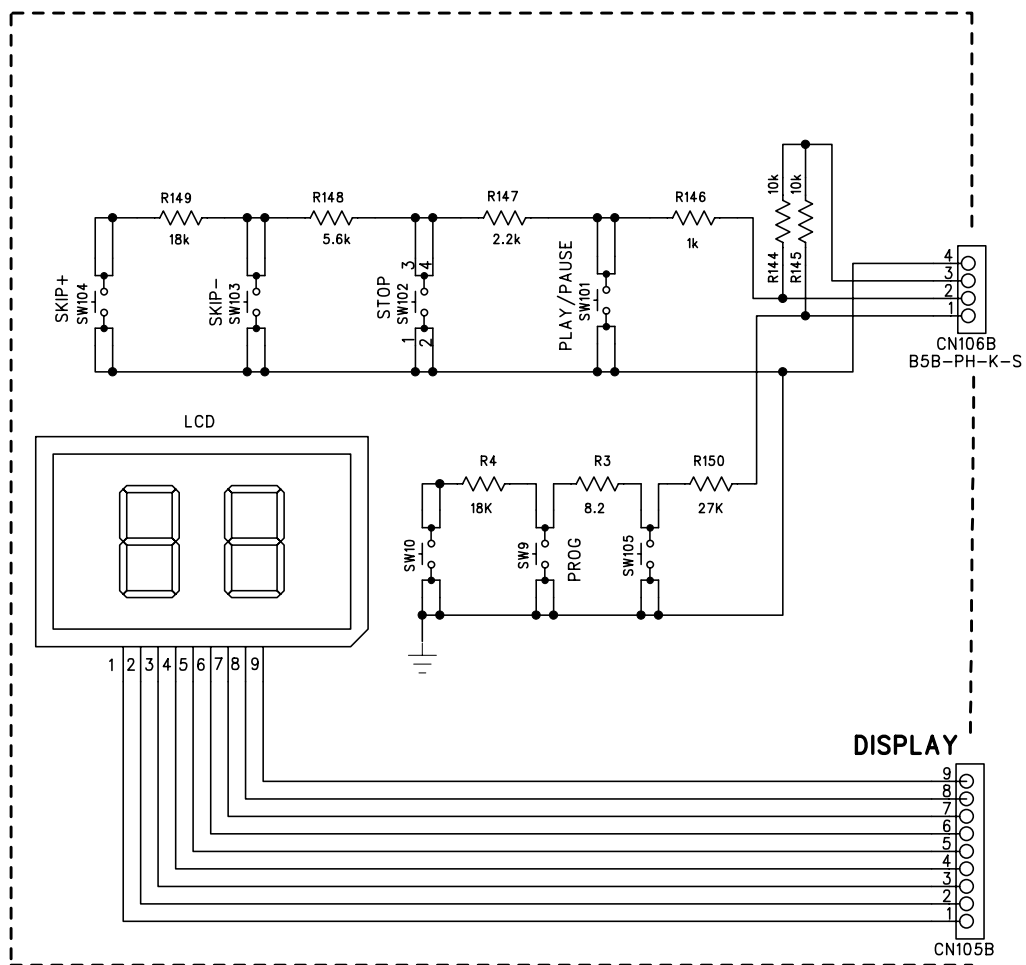

CD KEY BOARD - LAYOUT DIAGRAM

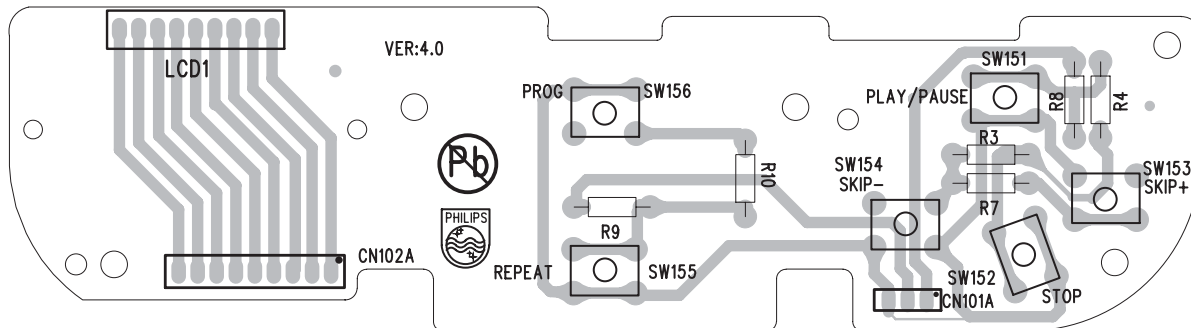

TUNER BOARD - CIRCUIT DIAGRAM

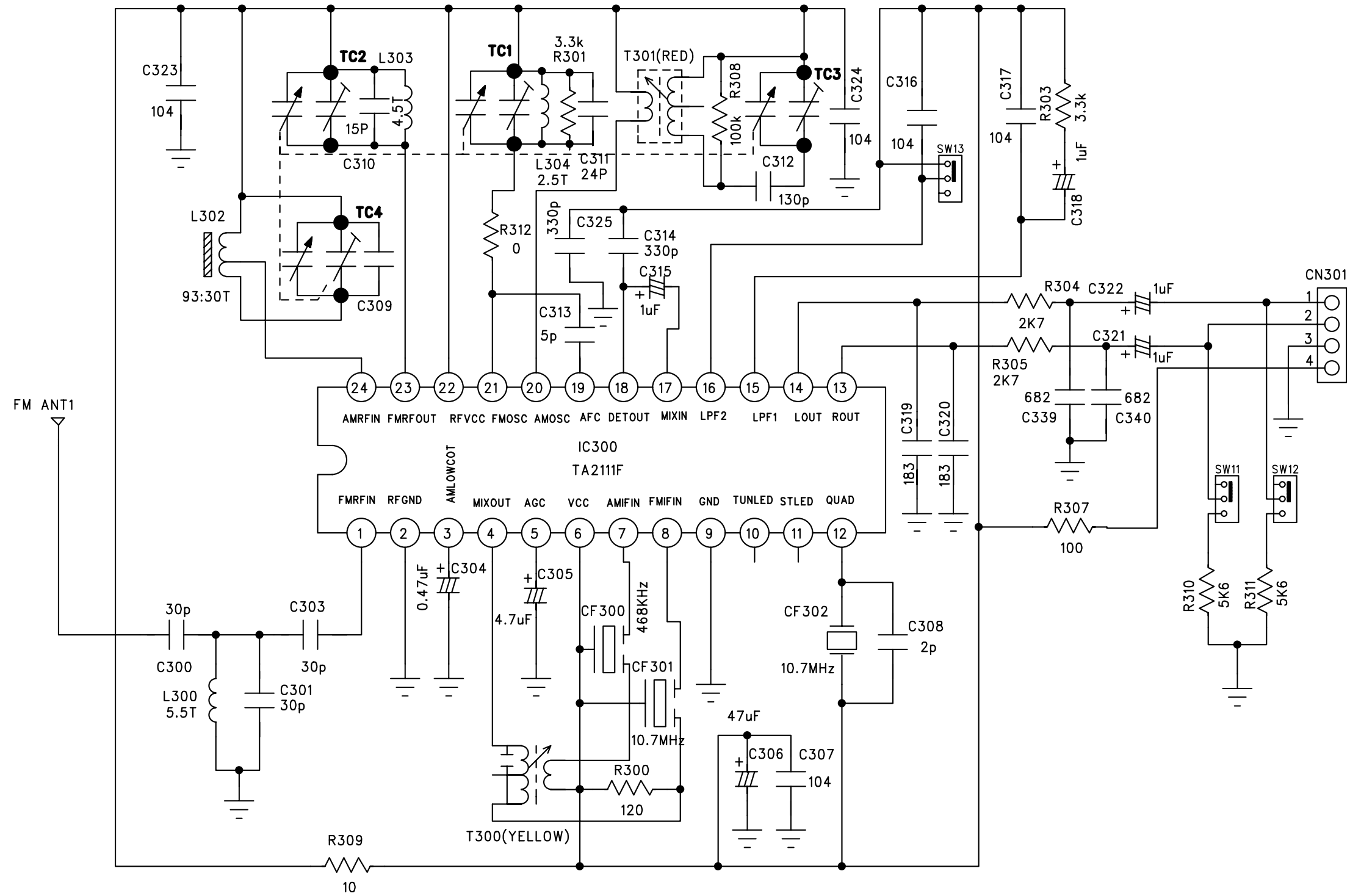

TUNER BOARD - LAYOUT DIAGRAM

COMPONENT SIDE

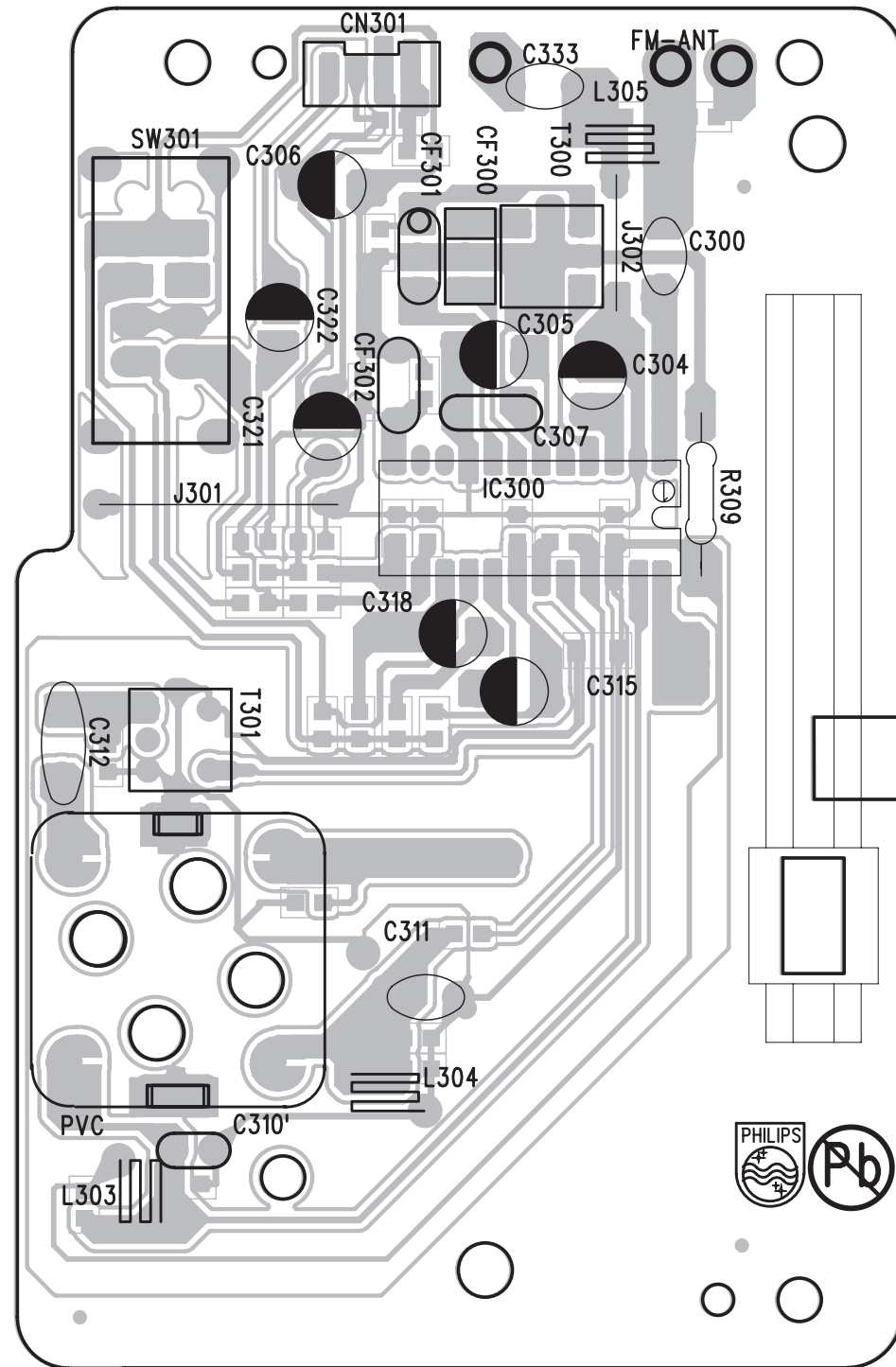

COPPER SIDE

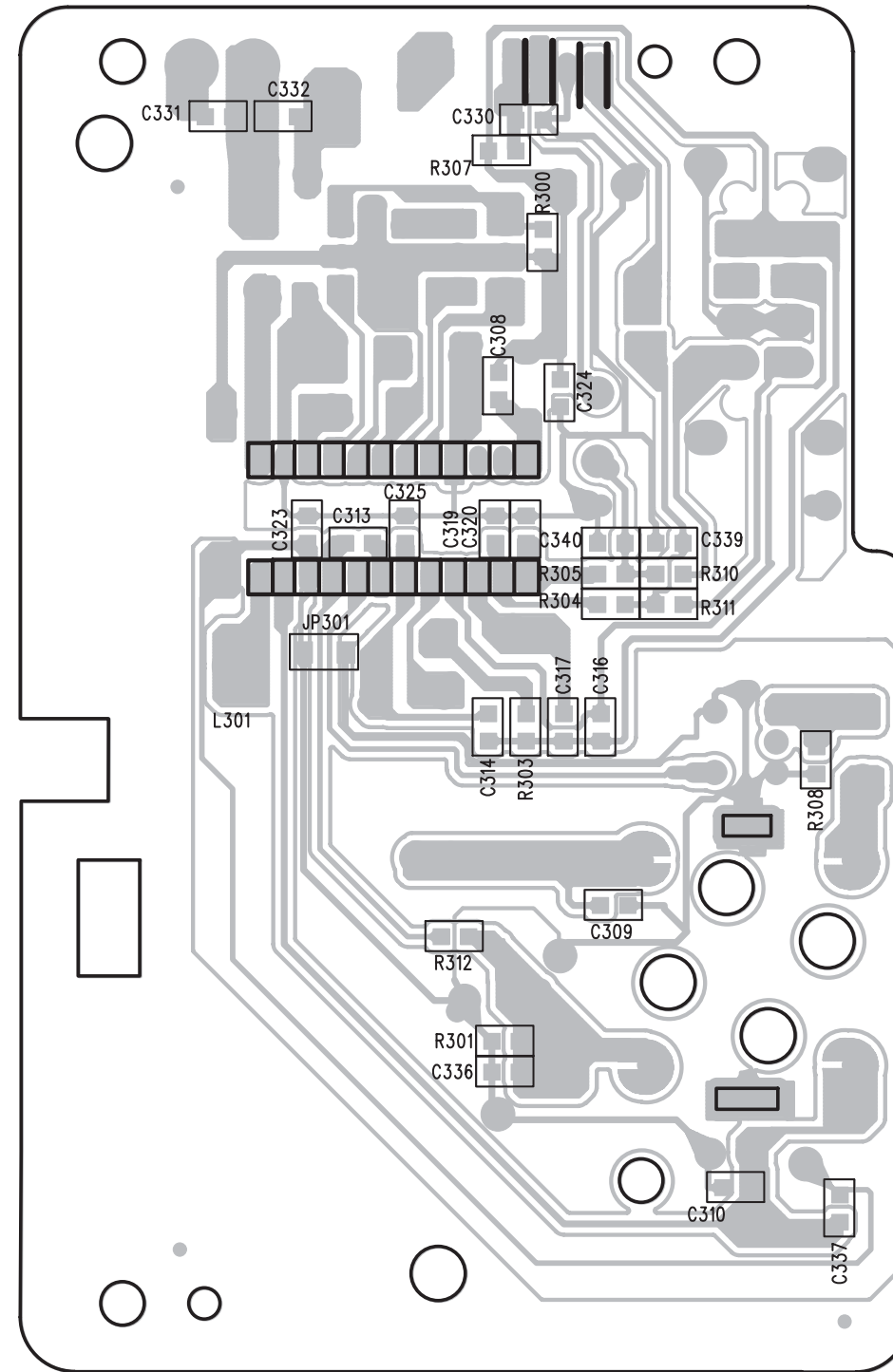

MAIN BOARD - CIRCUIT DIAGRAM (CD)

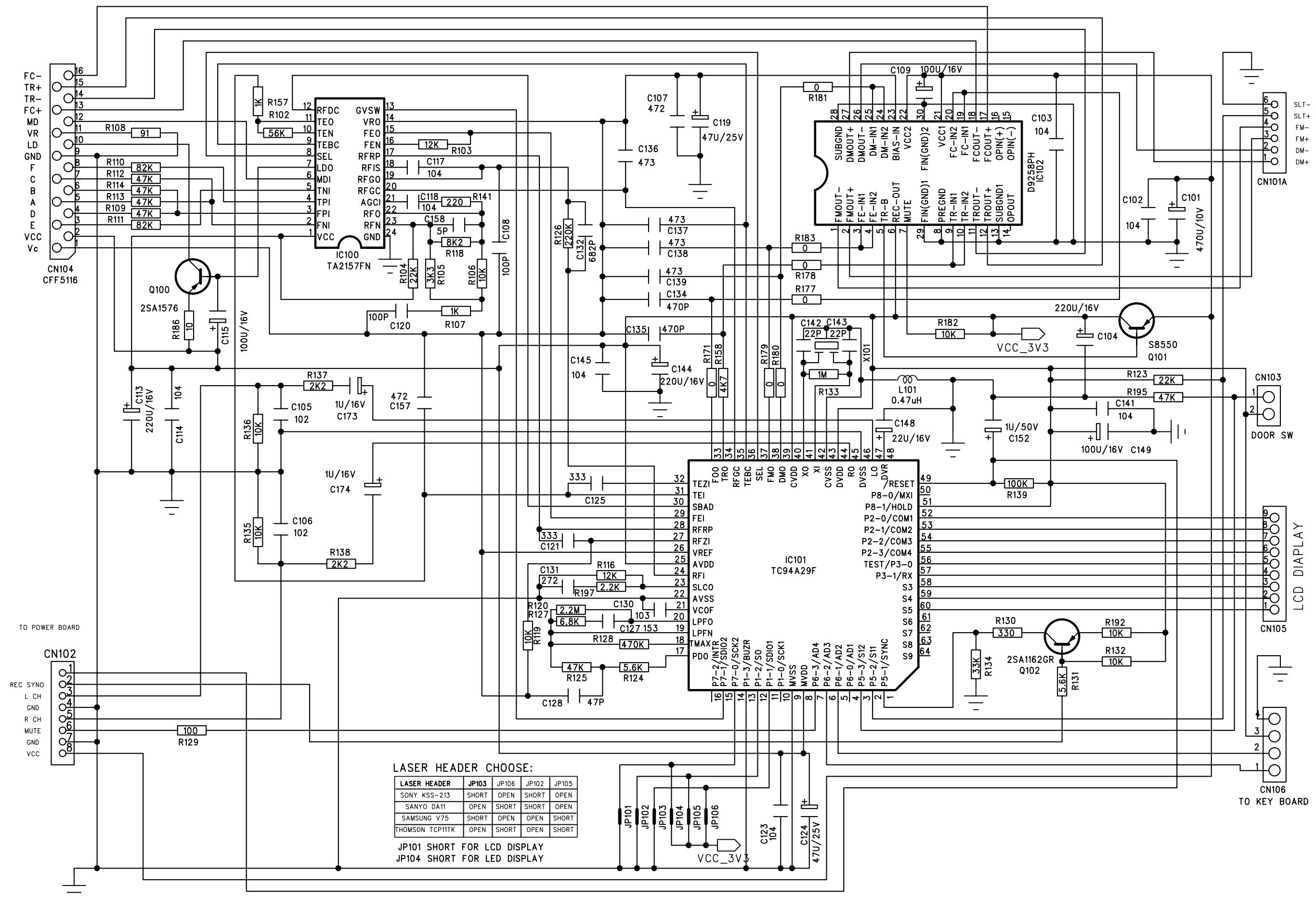

LASER HEADER CHOOSE:

LASER HEADER	JP103	JP106	JP102	JP105
SONY KSS-213	SHORT	OPEN	SHORT	OPEN
SANYO DA11	OPEN	SHORT	SHORT	OPEN
SAMSUNG V75	SHORT	OPEN	OPEN	SHORT
THOMSON TCP11TK	OPEN	SHORT	OPEN	SHORT

JP101 SHORT FOR LCD DISPLAY
 JP104 SHORT FOR LED DISPLAY

MAIN BOARD - CIRCUIT DIAGRAM (POWER AMP)

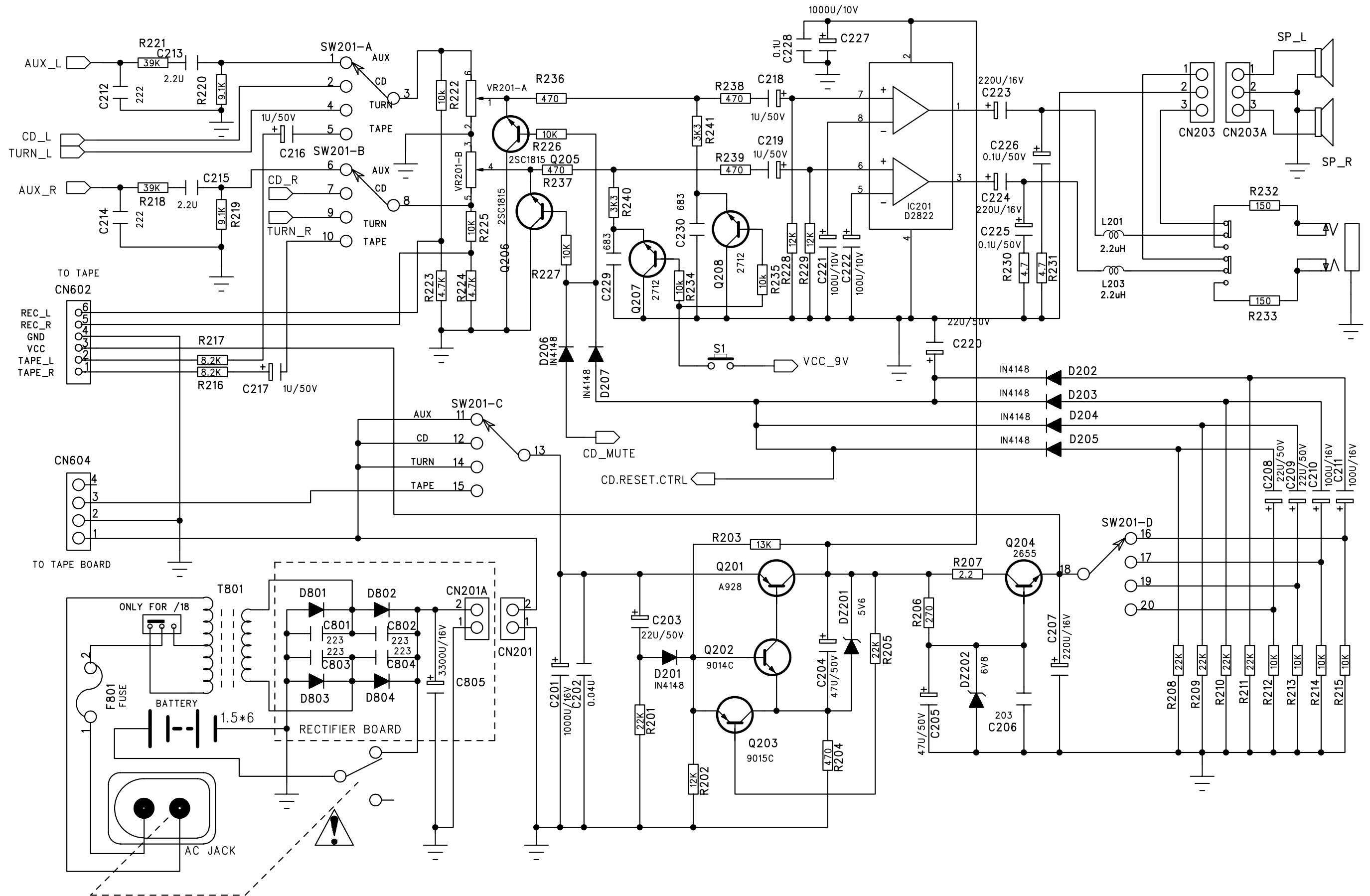

MAIN BOARD - CIRCUIT DIAGRAM (CASSETTE)

